

Rectangular ducting

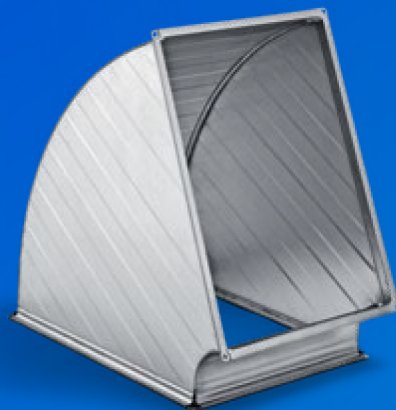

Air Conduction

Every HVAC system requires many different parts and components to transport air efficiently.

In its ducting range, BerlinerLuft. offers products and components for to construct complete rectangular or round ducting systems.

Rectangular ducting components	32
Flexible connectors (expansion joints)	61
Round ducting	70
Fresh air and exhaust air systems	73
Weather protection grilles	136
Ventilation towers and steel chimneys	166

Overview of folded ducting components

FOLDED DUCTING COMPONENTS – GALVANISED STEEL

Folded sheet metal ducts and fittings with rectangular cross section as per DIN EN 1505, 1507 and DIN 18379

Material: Sendzimir galvanised sheet steel

Grade: DX51D + Z275MA-C (DIN EN 10346 and DIN EN 10143)

Sheet thickness: for pressure rating L, M, HR

Airtightness classes: A, B and C as per DIN EN 1507

Turning vanes as per DIN EN 1505

Longitudinal seams folded, end connection with frame or slip joint

Walls reinforced with trapezoidal corrugation

Additional reinforcement for pressure ratings M and H^R as per BerlinerLuft. Technik GmbH factory standard

Standard duct section length 1500 mm (also with frame)

Width of frame sections for pressure rating L

Frame width 20 mm: up to edge length 1000 mm

Frame section width 30 mm: > edge length 1,000 to 2 000

Frame section width 40 mm: > edge length 2,000 mm

FOLDED DUCTING COMPONENTS – STAINLESS STEEL 1.4301 FOLDED DUCTING COMPONENTS – STAINLESS STEEL 1.4571

Sheet metal ducts and fittings with rectangular cross section similar to EN 1505, 1507 and DIN 18379

Folded sheet metal ducts and fittings made of stainless steel 1.4301 or 1.4571 (surface 2B as per DIN EN 10088)

Sheet thickness 0.8 mm and 1.0 mm, corners sealed or whole joint sealed (corners, frames, and seams)

Longitudinal seams folded, end connection with frame, turning vanes as per DIN EN 1505, walls reinforced with corrugations, additional reinforcement as per BerlinerLuft. factory standard, spot welds treated

Standard duct section length 1,500 mm

Width of frame sections for pressure rating L

Frame section width 20 mm: up to edge length 1,000 mm

Frame section width 30 mm: > edge length 1,000 to 2,000 mm



Overview of folded ducting components

FOLDED DUCTING COMPONENTS – ALUMINIUM

Sheet metal ducts and fittings with a rectangular cross section similar to EN 1505, 1507 and DIN 18379

Folded sheet metal ducts and fittings made of aluminium AlMg3

Sheet thickness 1.0 mm and 1.2 mm, corners sealed or whole joint sealed (corners, frames, and seams)

Longitudinal seams folded, end connection with frame, turning vanes as per DIN EN 1505, walls reinforced with corrugations, additional reinforcement as per BerlinerLuft. factory standard

Standard duct section length 1,500 mm

Width of frame sections for pressure rating L

Frame section width 20 mm: up to edge length 700 mm

Frame section width 30 mm: > edge length 700 to 2,000 mm

FOLDED DUCTING COMPONENTS – GALVANISED STEEL, INDUSTRIAL DUCTING

Sheet metal ducts and fittings with rectangular cross section for harsher conditions

Sheet metal ducts and fittings, folded, made of sendzimir galvanised thin sheet metal, quality DX51D + Z275MA-C (DIN EN 10346 and DIN EN 10143),

Sheet metal thickness up to 1,000 mm, edge length 0.95 mm, from 1,001 mm to 2,000 mm, edge length 1.15 mm, airtightness class A or B in accordance with DIN EN 1507, longitudinal seams folded, end connection with frame

Turning vanes as per DIN EN 1505

Walls corrugated, additional reinforcement using 30 mm standing seam and U-section support 30×50×30 mm

Suitable for pressure of -1,500 Pa to +3,000 Pa and high air velocities.

Standard duct section length 1,000 mm

Width of frame sections for pressure rating H^R

Frame section width 30 mm: up to edge length 1,000 mm

Frame section width 40 mm: > edge length 1,000 mm



Overview of folded ducting components, welded

FOLDED DUCTING COMPONENTS – GALVANISED STEEL, INSULATED

Sheet metal ducts and fittings with rectangular cross section, galvanised, folded and insulated

Sheet metal ducts and fittings made of Sendzimir galvanised thin sheet steel grade DX51D + Z275MA-C (DIN EN 10346 and DIN EN 10143)

Sheet thickness depending on pressure rating L or M

Airtightness class A or B as per DIN EN 1507

Folded longitudinal seams, end connection with frame

Turning vanes as per DIN EN 1505. Walls reinforced with corrugations, additional reinforcement as per BerlinerLuft. factory standard

Standard duct section length 1,500 mm

Width of frame sections for pressure rating L

Frame section width 20 mm: up to edge length 1,000 mm

Frame section width 30 mm: > edge length 1,000 to 2,000 mm



WELDED DUCTING COMPONENTS – SHEET STEEL

Welded sheet metal ducts and fittings with rectangular cross section as per DIN EN 1505, 1507 and VDI 3803

Welded sheet metal ducts and fittings made of Sendzimir galvanised thin sheet steel grade DX51D + Z275MA-C (DIN EN 10346 and DIN EN 10143) and black sheet S 235 JRG2 as per DIN EN 10025

Sheet thickness for pressure rating H^R

Airtightness class C and D as per DIN EN 1507

End connection with angle frame or formed frame, perforated as per factory standard (hole spacing 125 mm), turning vanes as per DIN EN 1505

Fixed duct length depending on the frame connection

Fixed duct length with flush angle frame: 1,500 mm

Recessed angle frame: 1,480 mm

30 mm formed frame 30/15: 1,350 mm

40 mm formed frame 40/20: 1,350 mm

60 mm formed frame 60/30: 1,300 mm

80 mm formed frame 80/40: 1,200 mm

Standard modular edging

40 mm: up to edge length 1,000 mm

60 mm: > edge length 1,000 mm

80 mm: > edge length 2,000 mm



Overview of folded ducting components, welded

WELDED DUCTING COMPONENTS – STAINLESS STEEL, MATT OR SHINY

Sheet metal ducts and fittings with rectangular cross section similar to DIN EN 1505, 1507 and VDI 3803

Welded sheet metal ducts and fittings made of stainless steel 1.4301 and 1.4571, matt or polished finish

Sheet thickness as required for airtightness class C or D as per DIN EN 1507. Stricter requirements such as nekal tightness as per DIN on request

End connection with angle frame or formed frame, perforated as per factory standard (hole spacing 125 mm), turning vanes as per DIN EN 1505

Fixed duct length depending on the frame connection

Fixed duct length with flush angle frame: 1,500 mm

Recessed angle frame: 1,480 mm

30 mm formed frame 30/15: 1,350 mm

40 mm formed frame 40/20: 1,350 mm

60 mm formed frame 60/30: 1,300 mm

80 mm formed frame 80/40: 1,200 mm

Standard modular edging

40 mm: up to edge length 1,000 mm

60 mm: > edge length 1,000 mm

80 mm: > edge length 2,000 mm

WELDED DUCTING COMPONENTS – ALUMINIUM

Sheet metal ducts and fittings with rectangular cross section similar to DIN EN 1505, 1507 and VDI 3803

Welded sheet metal ducts and fittings made of aluminium AL 99.5 hh and AlMg3, sheet thickness 2.0 mm and 3.0 mm

Airtightness class C and D as per DIN EN 1507. Stricter requirements such as nekal tightness as per DIN on request

End connection with angle frame, perforated as per factory standard (hole spacing 125 mm), turning vanes as per DIN EN 1505

Fixed duct length depending on the frame connection

Fixed duct length with flush angle frame: 1,500 mm

Recessed angle frame: 1,480 mm

30 mm formed frame 30/15: 1,350 mm

40 mm formed frame 40/20: 1,350 mm

60 mm formed frame 60/30: 1,300 mm

80 mm formed frame 80/40: 1,200 mm

Standard modular edging

40 mm: up to edge length 1,000 mm

60 mm: > edge length 1,000 mm

80 mm: > edge length 2,000 mm



Design of ducting components – frames

PLANNING REQUIREMENTS

Ducting components are part of the ducting system in central ventilation systems. When planning the ducting system, various requirements have to be met:

Optimised air flow

Ability to withstand pressure (VDI 3803)

Airtightness class (DIN EN 1507)

Hygiene requirements (VDI 6022)

Type specification (folded or welded)

Selection of material according to the type of air carried, for example: normal room air, dusty process air, chemically polluted air

Design of rectangular ducting components

Welded air duct with folded frame (3)

Mandatory for the strictest requirements of airtightness class D (e.g. decontaminable design)

Welded air duct with angle frame (4)

Can be used for special requirements of airtightness class D

- 1 | Folded air duct with formed frame
- 2 | Folded air duct with attached frame
- 3 | Welded air duct with folded frame
- 4 | Welded air duct with angle frame



Sheet metal ducts and fittings

AS PER DIN EN 1505, 1507 AND DIN 18379

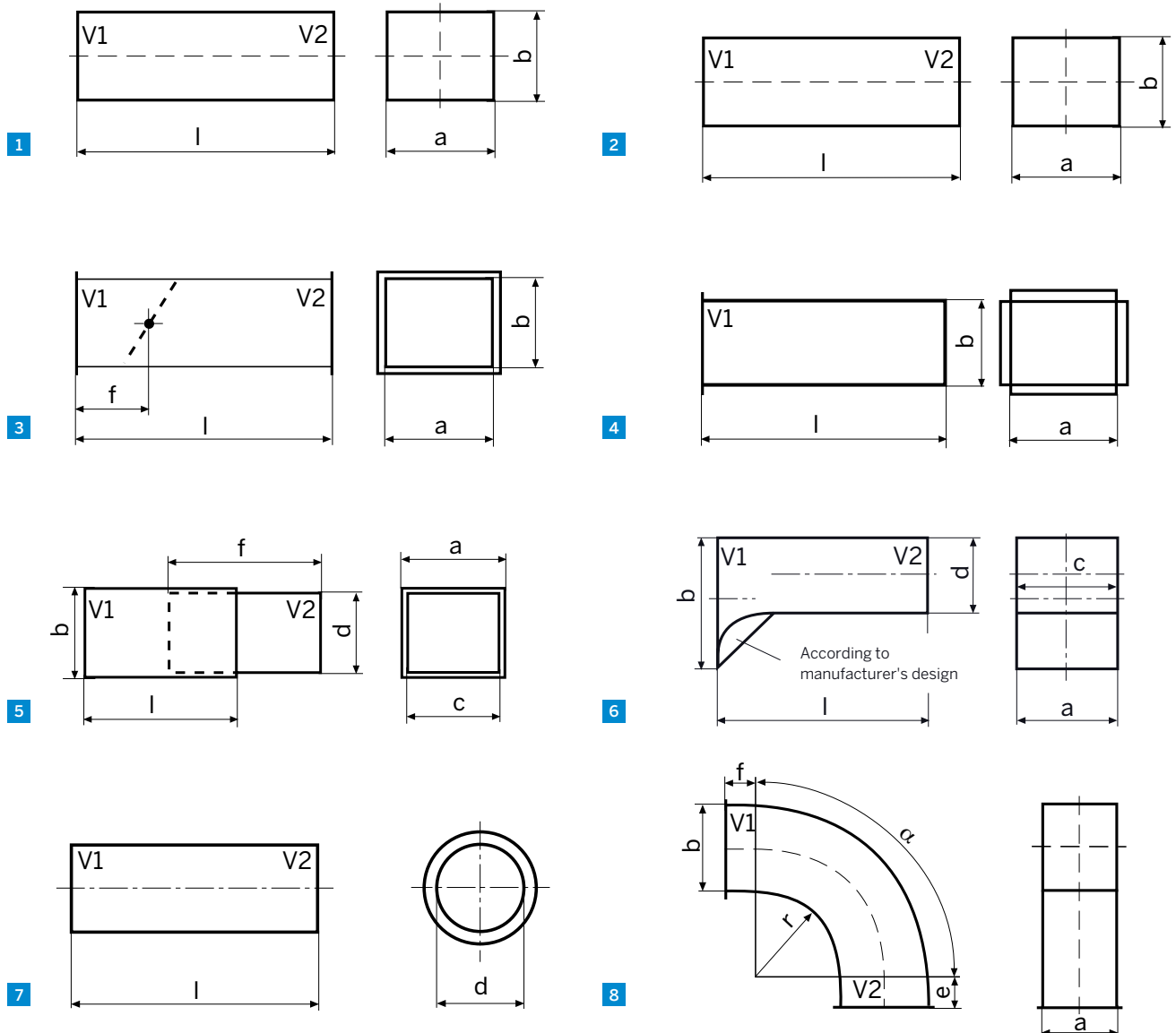

- 1 | K – Duct $l > 900$
- 2 | KT – Duct section $l \leq 900$
- 3 | KD – Duct with damper
- 4 | KS – Duct connector

- 5 | SS – Sliding connector
- 6 | SU – Transition connector
- 7 | SR – Round connector
- 8 | BS – Bend

AS PER DIN EN 1505, 1507 AND DIN 18379

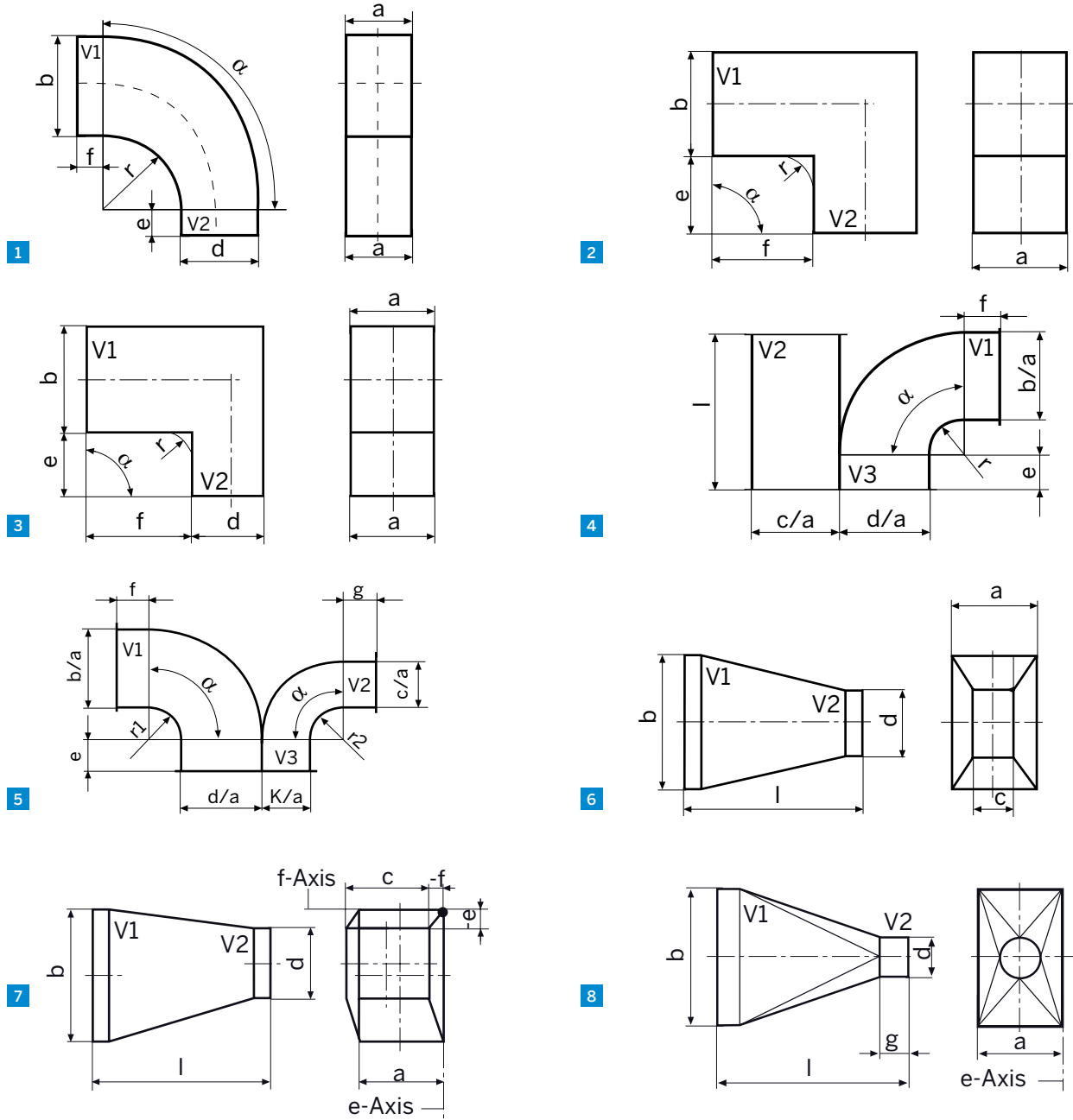

- 1 | BA - Transition bend
- 2 | WS - Symmetrical square bend
- 3 | WA - Square transition bend
- 4 | KOM - Combined bend/duct
- 5 | KOM - Three combined bend/bend
- 6 | US - Symmetrical transition
- 7 | UA - Asymmetrical transition
- 8 | RS - Symmetrical square to round transition

Sheet metal ducts and fittings

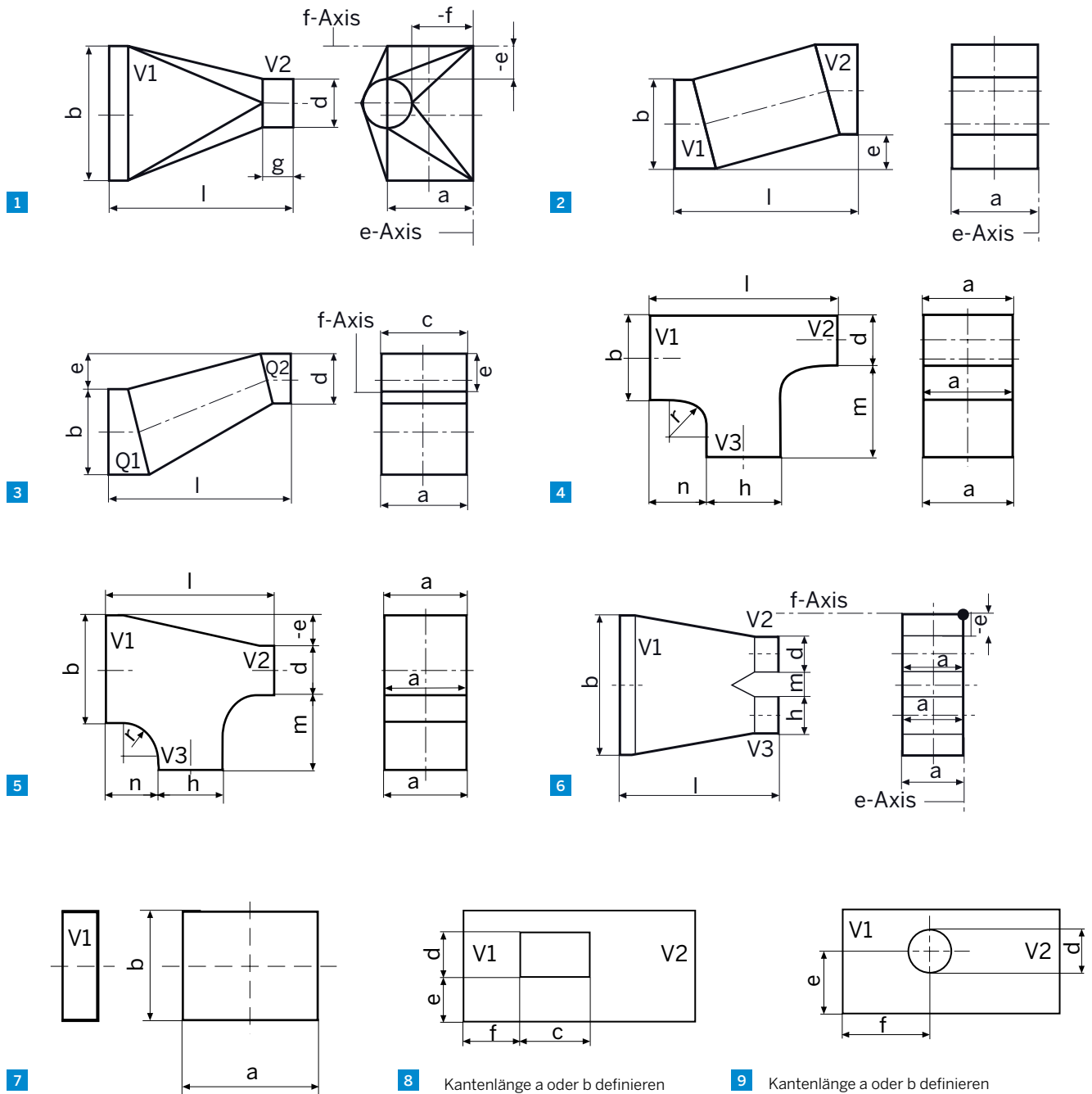

- 1 | RA – Asymmetrical square to round transition
- 2 | ES – Symmetrical offset
- 3 | EA – Asymmetrical offset
- 4 | TG – Straight T-piece
- 5 | TA – Diagonal T-piece

- 6 | HS – Y-piece
- 7 | BO – Base
- 8 | AE – Rectangular cut-out
- 9 | AR – Round cut-out

Table of ducting components

Technical requirement	Material					
	Galvanised steel	Black steel	Stainless steel	FAL	Aluminium	Platal
Design						
Folded	•		•		•	•
Welded	•	•	•	•	•	
Connection						
Frame	•		•		•	•
Slip joint	•	•	•	•	•	
Screw connection	•	•	•	•	•	
Welded butt joint		•	•	•		
Airtightness						
Airtightness class B	•		•		•	
Airtightness class C	•		•		•	
Airtightness class D	•	•	•	•	•	•
Aerosol-tight	•		•		•	•
Surface						
Hot-dip galvanised		•				
Primed/painted	•	•			•	
Chlorine-resistant paint	•	•				
Fatty acid-resistant paint	•	•				
Powder coating	•	•	•		•	
Insulation						
Double wall	•		•		•	•
Mineral wool/perforated plate, inside	•		•		•	
Cellular rubber internal/external	•	•	•	•	•	•
Anti-drone coating	•		•		•	

Standards and guidelines

STANDARDS AND GUIDELINES

HVAC is undergoing a period of upheaval in terms of standards and regulations: Some of the DIN standards have been withdrawn and replaced by EN standards. Although there is basic freedom of contract, withdrawn DIN standards may no longer be used.

In a legal dispute, only the EN standards apply.

This means that there is always an obligation to check that the standards are up to date.

Here is a list of standards which must always be observed for ducting:

DIN EN 1505	Sheet metal air ducts and fittings with rectangular cross section – Dimensions
DIN EN 1507	Sheet metal air ducts with rectangular section – Requirements for strength and leakage
DIN EN 12097	Requirements for ducting components to facilitate maintenance of ducting systems
DIN EN 12236	Ductwork hangers and supports
DIN EN 12599	Test procedures and measurement methods to hand over air conditioning and ventilation systems
DIN EN 16798-3	Ventilation of non-residential buildings
DIN 18379	VOB Part C – General technical specifications in construction contracts
DIN 18869-4	Equipment for commercial kitchens – Components for ventilation
DIN 24193-1*	Ducting components for ventilation equipment; flanges; series 1 angle flanges
DIN 24193-2*	Ducting components for ventilation equipment; flanges; series 2 angle flanges
DIN 1946-4	Ventilation systems in hospitals
VDI 2052	Air-conditioning – Kitchens (VDI Ventilation Code of Practice)
VDI 2087	Air ducting system – Operating and construction fundamentals
VDI 2089	Building services in swimming baths
VDI 3803	Central air-conditioning systems – Structural and technical principles
VDI 6022	Hygiene requirements for ventilation and air-conditioning systems and units

* DIN 24193 Parts 1 and 2 have been withdrawn. However, they can be used by mutual agreement, as no equivalent EN standard exists.

CERTIFICATE OF CONFORMITY WITH VDI 6022

The sheet metal ductwork made by BerlinerLuft. Technik GmbH is certified as adhering to the hygienic conformity assessment as per VDI 6022 sheet 1, and is available under the following registration numbers: **HKP 02/19 – 01 to 13.**

Materials

METALLIC MATERIALS

Ducting can be made from different metallic materials, depending on the application.

FOLDED AND WELDED DESIGN

Material type	Grade	Standard	tmax (°C)
Galvanised steel (Sendzimir galvanised thin sheet steel)	DX51D + Z275 MA-C	DIN EN 10346 DIN EN 10143	+200 °C to +250 °C
Stainless sheet steel (surface 2 B)	1.4301 (V2A) 1.4571 (V4A)	DIN EN 10088	+ 500 °C
Aluminium	AlMg3	DIN EN 485 DIN EN 573-3	+ 160 °C
FAL (hot-dip aluminised sheet steel)		DIN EN 1396	+ 700 °C
Platal (folded ducting only)	DX51D + ZA255 OS: 200 µm PVC article no... US: 5 µm + K-	DIN EN 10346 DIN EN 143	-20 °C/+80 °C
Black sheet steel (welded ducting only)	S 235 JRG 2	DIN 10130	+ 250 °C
Sealants ¹² Single-component sealant Basis:	Silicone-free Acrylic Silyl modified polymer (SMP) Resistant to fatty acids Permanently elastic and UV-resistant	VDI 6022	+ 80 °C Certified

¹ For all seals, only silicon-free materials are used

² Special seals for specific applications are available on request

SURFACE FINISH

Ducting can be made from different metallic materials, depending on the application. The surface finish and corrosion protection depend on the requirements.

The necessary coating thickness depends on the application and must be specified by the user, taking into account the relevant corrosion protection guidelines. A surface finish can be applied to the either black or galvanized sheet steel.

Black and galvanised sheet steel

Surface preparation/washing and passivation

Undercoat or primer

Painting

Powder coating

EPD coating (see page 450)

Stainless steel

Pickling and neutralisation

Blasting

Grinding

Brushing

Sheet thickness and pressure ratings as per VDI 3803

Nominal dimensions (edge lengths) ^{1,2} as per EN 1505		Wall thickness s [mm] ³							
		Folded ducting						Welded ducting	
		Low pressure L		Medium pressure M		High pressure H ^R		High pressure H	
		Max. pressure		Max. pressure		Max. pressure		Max. pressure	
a	b	Pa +1000	Pa -500	Pa +2000	Pa -750	Pa +3000	Pa -1500	Pa +6000	Pa -2500
100	100	0.6		0.7		1.0		1.5	
150	150								
200	200								
250	250								
300	300	0.8		0.9		1.0		2.0	
400	400								
500	500								
600	600								
800	800	1.0		1.1		1.2		3.0	
1000	1000								
1200	1200								
1400	1400								
1600	1600	1.0		1.1		1.2		3.0	
1800	1800								
2000	2000								
Nominal dimensions outside DIN EN 1505 > 2000 to 3000		Special non-standard components are manufactured on request. For the tender specification, the customer must state specific requirements for the sheet thickness and frame joint. They will be invoiced as special components.							

¹ Edge lengths a and b can be combined as desired

² For intermediate sizes, the sheet thickness is the one stated for the next higher edge length

³ The wall thickness is the nominal thickness as per DIN 10143

H^R Folded industrial design for restricted high pressure use with increased sheet thickness and additional reinforcement (available in airtightness class B), max. duct length 1,000 mm

Turning vanes

ARRANGEMENT OF TURNING VANES IN 90° BENDS AS PER DIN EN 1505 ¹

Width of ducting [mm]	Number of turning vanes	Space between turning vanes (approximate) [mm]		
		b1	b2	b3
$400 < b \leq 800$	1	b/3	-	-
$800 < b \leq 1600$	2	b/4	b/2	-
$1600 < b \leq 2000$	3	b/8	b/3	b/2

Note: Bends up to 45° do not contain turning vanes

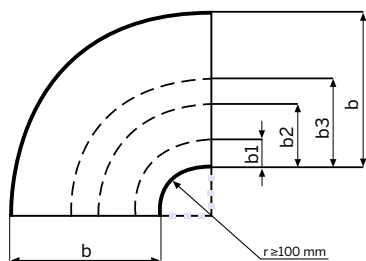

As standard, the turning vanes are fastened with sealed studs.

- ¹ Turning vanes as per DIN EN 1505
Edge length b as per DIN 18379 (VOB Part C)

Airtightness

AIRTIGHTNESS

To ensure that the air conditioning system operates reliably and energy-efficiently, the ducting must meet specific airtightness requirements. DIN EN 1507 defines the permissible leakage rate per m² of ducting surface, depending on the static internal pressure.

Diagram 1 can be used to estimate the expected leak loss for a ducting system or one of its sections. Starting with the

average internal pressure¹, the leakage rate is read off of the diagram and multiplied by the duct surface area. The table below shows the airtightness requirements in DIN EN 1507 and the recommendations for use in DIN EN 16798-3 and VDI 3803.

¹ Static pressure difference between the internal duct pressure and the ambient pressure (both positive and negative pressure)

Airtightness class as per DIN EN 1507	Airtightness class as per DIN EN 16798-3	Maximum air leakage m ³ x s ⁻¹ x m ⁻²	Use recommendation as per VDI 3803
A	ATC 5	0.027 x p ^{0.65} x 10 ⁻³	Not recommended
B	ATC 4	0.009 x p ^{0.65} x 10 ⁻³	Minimum requirement
C	ATC 3	0.003 x p ^{0.65} x 10 ⁻³	Standard requirement
D	ATC 2	0.001 x p ^{0.65} x 10 ⁻³	Maximum requirement

p = static interior pressure

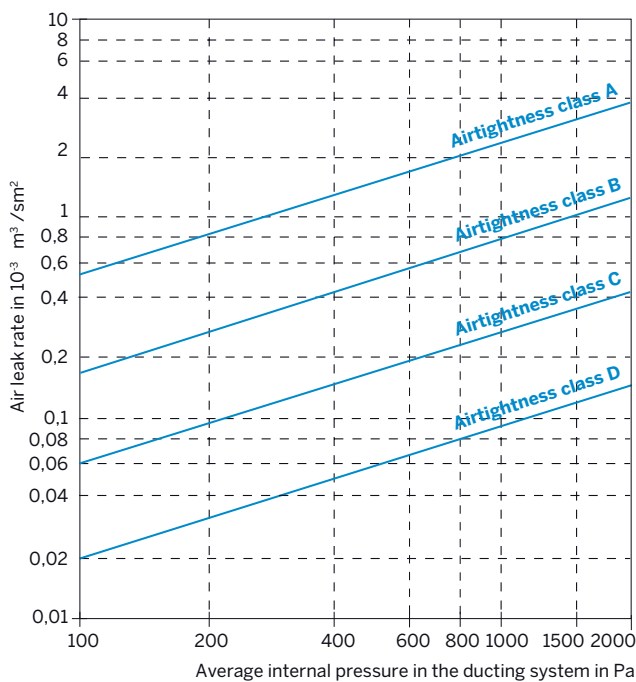

Diagram 1

PROOF OF AIRTIGHTNESS

The airtightness class must be certified on an installed section of the ductwork, containing a representative number of ducts and fittings and a surface area of at least 10 m² (see DIN EN 1507, measuring procedure in DIN EN 12599).

The quality of installation has a significant effect on the airtightness of the ducting. In order to achieve a particular airtightness class, all components designed for the class in question must be produced at a high quality, and the installation must be carried out according to exacting standards. To monitor the quality of installation, it is advisable to carry out a sample test of the leak rate in accordance with DIN EN 15599 during the assembly phase.

Energy savings from use of airtightness class C

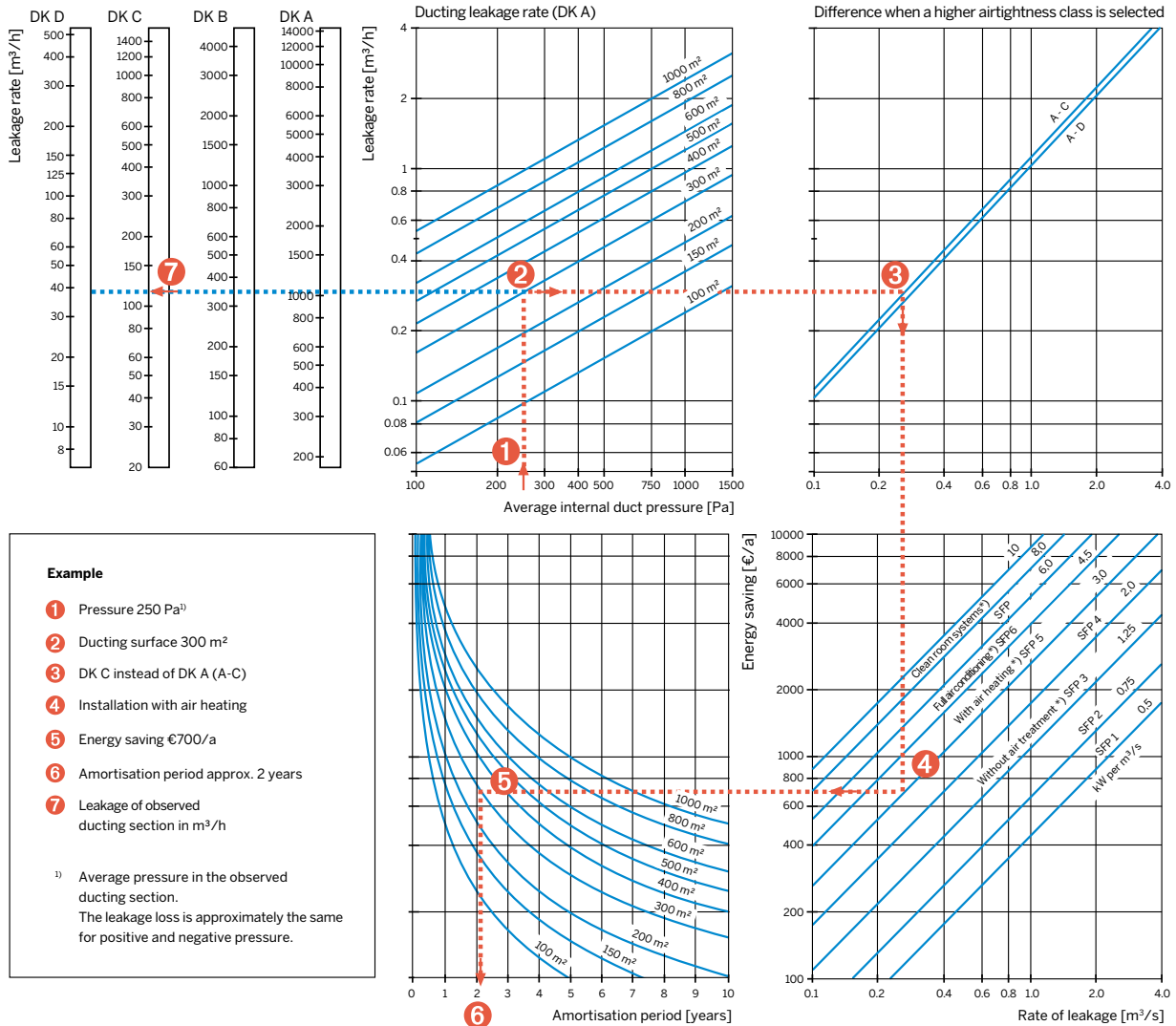

* The assignment of SFP classes to the type of system only includes the cost of ducting (as a rough guide)

Comparison: advantages of using airtightness class C instead of class A, which typically has been used up to now

The amortisation period is calculated using the following formula, using current cost developments and the operating time:

The diagram is based on the following assumptions:

Energy costs 10 cents/kWh

System operated 24 hours a day

Additional cost of ducting €5.00/m²

$$A \text{ [years]} = \frac{10 \text{ cts.}}{EC \text{ [ct.]}} \times \frac{OT \text{ [h]}}{[h]} \times \frac{AC \text{ [€]}}{€5}$$

- A: Amortisation period
- EC: Actual energy costs per kWh
- OT: Average operating time
- AC: Additional cost of the ducting system per m²

Component joints — maximum and minimum dimensions

Pressure rating	Section connection,				Folded flange	Angle flange	Straight flange
	LP C+ ¹		LP ²				
	L	M	L	M	H	H	H
edge length	[mm]	[mm]	[mm]	[mm]	[mm]	[mm]	[mm]
0 to 500	20	20	20	20	40	30 × 3	30 × 5
501 to 1000							40 × 5
1001 to 1250	30	30	30	30	40		60 × 6
1251 to 2000						40 × 4	
> 2000³			40	40	40	50 × 5	60 × 10

¹ LP C+¹ formed frame on ducting and fitting (except US, UA, HS, BE, BD)

² LP¹ attached frame for the above fittings and special parts

³ components with edge lengths greater than 2,000 mm are non-standard and are manufactured as special parts.

The type of component joint must be specified by the user according to the requirements of use.

COMPONENT REINFORCEMENTS

The reinforcements on duct walls are based on the component requirements in DIN EN 1507 as regards limit values for rigidity and stability of form.

The specific requirements are compiled in an internal factory standard.

Generally, the following types of reinforcement are used. Walls of duct and fittings up to a sheet thickness of 1.25 mm generally have a trapezoidal corrugated profile.

BerlinerLuft. trapezoidal corrugations have profile depths and flank angles that optimise flow and are classified as smooth-walled according to VDI 6022.

For certain pressure ratings and component dimensions, additional side wall reinforcements are required. These take the form of



Internal tubular supports

Internal or external sheet metal rails

External ribs

(only on welded ducting when necessary)

Flange connections

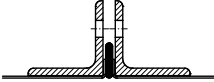
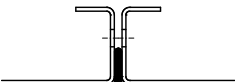
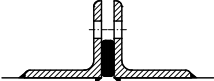
Folded and welded components					
Flange designation	Code	Diagram	Connected ¹ using	Standard component length duct [mm]	
Folded components	Section connection, formed	LP C		4-hole corner joint plus duct clamps	1500
	Section connection, attached	LP		4-hole corner joint plus duct clamps	1500
	Angle flange, recessed	W 1		Bolted joint Hole spacing 125 mm or special hole spacing	1480
Welded components	Welded components Folded flange Modular edging Corners closed	WA		Bolted joint Hole spacing 125 mm or special hole spacing	1350 at 40/20 mm forward/backward fold
	Angle flange, welded flush	W 2		Bolted joint Hole spacing 125 mm or special hole spacing	1500

¹ Observe the assembly recommendation

Assembly recommendation

FOR JOINTS (FLANGES) OF DUCT COMPONENTS

Pressure range Pa	Pressure rating	Airtightness class	Sealing material for flange	Spacing of duct brackets or bolted joints
+1000/-500	L	A	Duct tape 12 x 6	for a or b > 750 max. 400 mm
		B	Duct tape 12 x 6	for a or b > 750 max. 400 mm
		C	Duct tape 12 x 6	for a or b > 400 max. 200 mm
+2000/-750	M	B	Duct tape 12 x 6	for a or b > 750 max. 400 mm
		C	Duct tape 12 x 6	for a or b > 400 max. 200 mm
+3000/-1500 (Folded industrial ducting)	HR	B	Duct tape 12 x 6	for a or b > 550 max. 300 mm
+6000/-2500	H	C	Duct tape 12 x 6	Hole spacing 125 mm
		D	Duct tape 12 x 6	Hole spacing 125 mm

HR Folded industrial design for restricted high pressure level with increased sheet thickness and additional reinforcement (available in airtightness class B), maximum duct length 1,000 mm

TOLERANCE RANGES

Sheet metal ducts

Edge length [mm]	Max. deviation [mm]
a or b	
100-1000	0 -3
1001-2000	0 -4
> 2000	0 -5
Component length [mm]	0.005 x L

Sheet metal fittings

Component dimensions	Max. deviation [mm]
a, b, c, d, e, f	0 -4
l, l_p, r	0 -5
> 15 / < 100 mm	
> 100	0 -4
> 2000	0 -10
Angle tolerance	+/-1°

Transport and storage

CLEANLINESS OF DUCTWORK (VDI 6022, SHEET 1)

Depending on the hygienic requirements, ducts and fittings may have to be protected from dirt during transport and on site storage or may have to be cleaned before assembly. In accordance with VDI 6022, sheet 1, requirements for the cleanliness of components are divided into cleanliness levels.

The standard version offered by the manufacturer are visibly clean, non-packaged components.

Other requirements (such as cleaning; closed ends; complete, single packaging or complete, multiple packaging) must be specified at the planning stage.

Cleanliness level	Packaging ex works	Protection during transport	Protection during storage	Cleaning on site	Sealing openings on site
Medium	No	No	Yes	Yes	Yes
High	Yes	Yes	Yes	Yes	Yes

COST CALCULATION UNITS

The cost of ducts and fittings is standardised and is based on the surface area in m².

The basis for this is: **DIN 18379**

German construction contract procedures (VOB)

Part C: General technical specifications in construction contracts (ATV)

Installation of air conditioning systems

The price is calculated per m² of component surface area. The calculation formulas are standardised for each component. The costs are calculated in price groups.

Straight ducts up to a component length of 900 mm are priced as fittings. The minimum size for price calculation is 1 m² per component.

Price calculation group		Maximum edge length [mm]
Ducting system (duct)	Fittings	
L1	F1	Up to 500
L2	F2	> 500 to 1000
L3	F3	>1000 to 1500
L4	F4	> 1500 to 2000
L5	F5	> 2000 (outside standard)

Special versions

KITCHEN EXHAUST AIR DUCTING

Ducting for kitchens is subject to special hygiene and safety requirements. The basis for this is DIN 18869 Part 4 and VDI 2052.

Exhaust air ducting in kitchens must be greaseproof and aerosol-proof. The following materials can be used: galvanised sheet steel and stainless steel (V2A 1.4301 or V4A 1.4571 or 1.4404)

RECOMMENDATIONS FOR USE

Ducting type	Galvanised steel	Stainless steel	Airtightness class	Seal	Notes
Fresh air/ incoming air	x	x	C	Grease-resistant Permanently elastic	Folded ducting with additional seal
Discharge air/ exhaust air	x	x	C	Folded and sealed	Not always possible, due to complex sealing during production and assembly
	x	x	D	Welded	Components are greaseproof and aerosol-proof, high quality of assembly required

Galvanised ducting through which aerosols might enter food processing areas must be coated with paint.

DUCTING FOR SWIMMING BATHS

Requirements for building services in swimming baths are specified in VDI 2089.

There are no special requirements for metal ventilation ducting in swimming baths. Some references are made to the requirements for ducting in kitchens.

In the case of ducting made of galvanised sheet steel, an offer will be made for additional painting of the component surfaces. The surface protection will be applied to the interior and/or the exterior surfaces as required by the intended use.

Exhaust and exhaust air systems exposed to chloride should preferably be made of V4A (1.4571 or 1.4404). All other materials require a multi-component coating inside and outside, depending on the application.

Thermal and acoustic insulation

INSULATION REQUIREMENTS FOR DUCTING

Reduced heat loss

Temperature dropping below dew point

Reduced sound emissions

Note

The customer must always check that the type and structure of the insulation is suitable for the application.

Exterior thermal insulation (self-adhesive cellular rubber)



Insulation thickness [mm]	Weight kg/m ²	U-value W/m ² C
19 mm		1736
up to EL 1000	8.4	
> EL 1000	9.5	

In addition to insulating after complete assembly of the ducting, there is also the option of using ready-insulated components. This option is used indoors when insulation after installation is not possible due to lack of space.

Double-wall thermal insulation Mineral wool with sheet metal shell

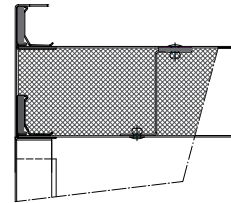

Insulation thickness [mm]	Weight kg/m ²	U-value W/m ² C
50		0.9
up to EL 1000	16	
> EL 1000	19	
100		0.45
up to EL 1000	17.5	
> EL 1000	20.5	

Sound insulation

Mineral wool with glass fibre fabric and perforated sheet metal shell

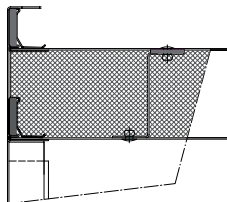

Insulation thickness [mm]	Weight kg/m ²
50	
up to EL 1000	12.5
> EL 1000	14
100	
up to EL 1000	15
> EL 1000	16.5

Smoke extraction — XDuct® smoke extraction duct

XDuct® is smoke extraction ducting made of galvanised steel as per DIN EN 12101-7 with CE marking. The test was carried out using 1500 Pa negative pressure and at 600 °C with 500 Pa negative pressure over a period of 120 minutes as per DIN EN 1366-9.

The smoke extraction ducting is a complete system with ducts and fittings made of folded, galvanised sheet steel and complies with the administrative requirements of the Technical Building Regulations. The tested system is impressive due to its lower pressure loss, reduced risk of transport damage, and lower weight. The installation is thus easier than other similar solutions made of calcium silicate panels. The ducts and fittings are made of 1 mm galvanised sheet steel with additional reinforcements and a 30 mm lightweight section frame.

Smoke extraction ducting with cross sections up to $W \times H = 1,250 \times 1,000$ mm are used. The installation material required for the XDuct® system (wall anchors, duct crossbeams, duct tape, sealing compound) is also subject to certification for fire safety and is also supplied on request. (DIN EN 12101-7, paragraph 4.2.5, other components)

XDuct® ventilation duct sections are branded with the CE conformity mark.

Accessories tested as per DIN EN 1366-9 are marked with the product code according to the classification report. A wide range of tested accessories, such as expansion joints, smoke extraction grilles, silencers, inspection panels are available. A height offset between duct axes of up to 2,500 mm is also available.



Duct accessories

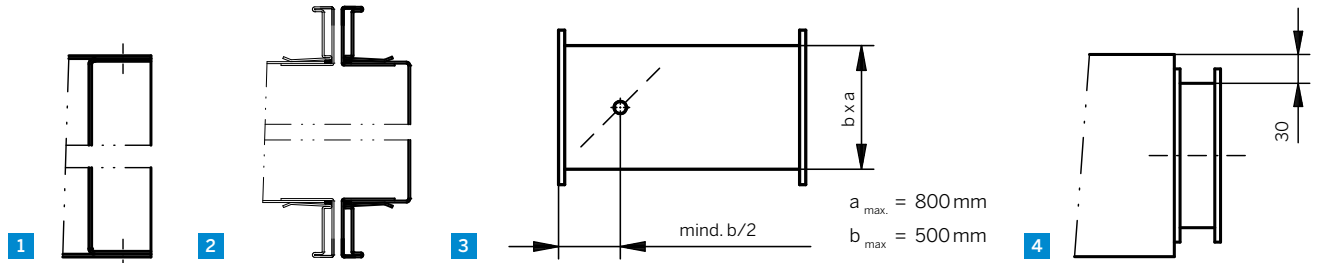

- 1 | Pre-fitted duct base
- 2 | Separate duct base
- 3 | Duct with damper
(damper adjuster with setting mark)
- 4 | Duct base with rectangular or round connector

INSPECTION PANEL – OVAL WITH TWO STAR KNOBS

Nominal size	Dimensions	RD	RD-SKK	RD-HT	IRD
Type		B	C	up to 400 °C	up to l thickness 50 mm
Airtightness class		-70 °C/+70 °C	-70 °C/+100 °C		
Range of application					
21	200 x 100	All listed types and dimensions are available in the following materials: galvanised steel, corrosion-resistant steel (V2A and V4A), aluminium			
32	300 x 200				
43	400 x 300				
54	500 x 400				
65	600 x 500				

- RD = Inspection panel
- RD-SKK = Inspection panel with self-adhesive edge guard
- RD-HT = Inspection panel for high temperatures
- IRD = Insulated inspection panel

Drain outlets	1/2" 3/4" 1.0" 1 1/2"
Connection angle frames for units Hole spacing 125 mm or special hole spacing	30 x 30 x 3 40 x 40 x 4 50 x 50 x 5
Installation material	Hex bolts M 8 x 25 Hex nuts M 8 Washers DN 9 Duct clamps C clamp (100 mm long) Self-adhesive installation tape (only for tightness class A) Butyl rubber sealing compound (for tightness class B, C, D)

Other accessories are available on request.

Tender specification texts

FOLDED GALVANISED STEEL DUCTS AND FITTINGS

Folded galvanised steel ventilation ducts and fittings as per DIN EN 1505, DIN EN 1507 and VDI 3803

Pressure rating L (low pressure); +1,000/-500 Pa

Pressure rating M (medium pressure); +2,000/-750 Pa

Sheet thickness depending on the pressure rating specified above

Components suitable for the assembly of ducting in

Airtightness class B, according to DIN EN 1507

BerlinerLuft. – B-duct ducting system or

Airtightness class C according to DIN EN 1507

Duct flange joint with 4-hole corner attachment, mainly with a touching duct section.

The additional seal on the seams and corners must be permanently elastic, water-insoluble, chemical-resistant and silicon-free.

Duct walls reinforced with BerlinerLuft. trapezoidal corrugated profile, with optimised tube friction coefficients.

Regarding the acoustics and aerodynamics, additional (internal) reinforcements must be made according to the operating pressure, sheet thickness and component dimensions and according to the factory standard.

Additional requirements (as necessary)

To ensure that the ducting is clean as per DIN EN 12097 or VDI 6022, sheet 1

Medium cleanliness level:

Delivery without packaging or transport protection, protection during storage, cleaning before assembly, openings sealed

High cleanliness level:

Delivery with packaging and transport protection (e.g. ends closed), protection during storage, cleaning before assembly, openings sealed

KITCHEN EXHAUST AIR DUCTING

(Text as above) The additional seal on the seams and corners must be permanently elastic, water-insoluble, chemical-resistant and silicon-free.

All components must be coated on the outside and/or inside with chemically resistant paint,
RAL colour

DUCTING FOR SWIMMING BATHS

(Text as above) The additional seal on the seams and corners must be permanently elastic, water-insoluble, chemical-resistant and silicon-free.

All components must be coated on the outside and/or inside with chemically resistant paint,
RAL colour

FOLDED STAINLESS STEEL DUCTS AND FITTINGS (1.4301 OR 1.4571)

Folded stainless steel ventilation ducts and fittings 1.4301 (1.4571)

Pressure rating L (low pressure); +1,000/-500 Pa

Pressure rating M (medium pressure); +2,000/-750 Pa

Sheet thickness min. 0.8 mm; max. 1.0 mm

Components suitable for assembling ducting systems in

Airtightness class B according to DIN EN 1507 BerlinerLuft.
– B-duct ducting system or

Airtightness class C as per DIN EN 1507

Duct flange joint with 4-hole corner attachment, with an attached duct section

The additional seal on the seams and corners must be permanently elastic, water-insoluble, chemical-resistant and silicon-free.

Duct walls reinforced with BerlinerLuft. trapezoidal corrugated profile, with optimised tube friction coefficients.

Regarding the acoustics and aerodynamics, additional (internal) reinforcements must be made according to the operating pressure, sheet thickness and component dimensions and according to the factory standard.

Additional requirements (as necessary)

To ensure that the ducting is clean as per DIN EN 12097 or VDI 6022, sheet 1

Medium cleanliness level:

delivery without packaging or transport protection, protection during storage, cleaning before assembly, openings sealed

High cleanliness level:

delivery with packaging and transport protection (e.g. end closure)

protection during storage, cleaning before assembly, openings sealed

KITCHEN EXHAUST AIR DUCTING

(Text as above) The additional seal on the seams and corners must be permanently elastic, water-insoluble, fatty-acid-resistant, aerosol-tight and silicon-free.

Tender specification texts

FOLDED VENTILATION DUCTS AND FITTINGS, INDUSTRIAL DESIGN, GALVANISED STEEL

Folded galvanised steel ducts and fittings

Pressure rating H^R (high pressure restricted); +3,000/-1,500 Pa

Sheet thickness min. 1.0 mm; max. 1.2 mm

Components suitable for assembling ducting

In airtightness class B according to DIN EN 1507 BerlinerLuft. B-duct ducting system

Duct flange joint with 4-hole corner attachment, with an attached duct section

The additional seal on the seams and corners must be permanently elastic, water-insoluble, chemical-resistant and silicon-free.

Duct walls reinforced with BerlinerLuft. trapezoidal corrugated profile, with optimised tube friction coefficients.

Regarding the acoustics and aerodynamics, additional (internal) reinforcements must be made according to the operating pressure, sheet thickness and component dimensions and according to the factory standard.

Additional requirements (as necessary)

To ensure that the ducting is clean as per DIN EN 12097 or VDI 6022, sheet 1

Medium cleanliness level:

Delivery without packaging or transport protection, protection during storage, cleaning before assembly, openings sealed

High cleanliness level:

Delivery with packaging and transport protection (e.g. ends closed), protection during storage, cleaning before assembly, openings sealed

WELDED VENTILATION DUCTS AND FITTINGS

Welded ventilation ducts and fittings as per DIN EN 1505, DIN EN 1507 and VDI 3803 made of

galvanised steel with cold galvanised welds

Stainless steel 1.4301 (1.4571), brushed welds

Aluminium AlMg3

Welds may not be ground

Pressure rating H (highpressure); +6,000/-2,500 Pa

Sheet thickness appropriate for the pressure level specified above and component cross-sections (see BerlinerLuft. documentation); however, must be at least 1.5 mm

Components suitable for assembling ducting in

Airtightness class D as per DIN EN 1507

Duct flange connections W1, W2, WA, F2 with 125 mm hole spacing as standard or special hole spacing.

External duct wall reinforcement depending on pressures stated in factory standard

Additional requirements (as necessary)

All components must be coated on the outside and/or inside with chemically resistant paint, RAL colour, coating thickness µm

To ensure that the ducting is clean as per DIN EN 12097 or VDI 6022, sheet 1

Medium cleanliness level:

Delivery without packaging or transport protection, protection during storage, cleaning before assembly, openings sealed

High cleanliness level:

Delivery with packaging and transport protection (e.g. ends closed), protection during storage, cleaning before assembly, openings sealed

Assembly information

FOR DUCTING REQUIRING AIRTIGHTNESS CLASS C ACCORDING TO DIN EN 1507

Several factors determine whether the airtightness class can be ensured. The fundamental requirement is that the components are carefully manufactured. The order must state which airtightness class is needed. Assembly on site is equally important as regards airtightness.

As the manufacturer, we would like to provide you with the necessary information.

Unloading and transporting components

Visually check all components for external damage.

Check that airtightness class C is correctly shown on the labels.

Unload the components with care to avoid any damage.

Use suitable equipment to transport the components (do not pull on the frame joint).

Store them in a proper manner on site.

Assembly

Visually check the components again for external damage.

Make sure the frame joint is clean.

Attach the duct tape flush with the inside edge of the duct section.

Attach the duct tape crosswise in the corner area of the section.

Make sure the bolt connections on the corners are tight.

Use duct brackets for edge lengths above 400 mm, with a maximum spacing of 200 mm.

About 2 days later, check that the bolt connections on the frame are tight (duct tape has settled).

Only use mating parts with the supplied loose frame (frames without internal sealant)

The loose frame is temporarily fixed on the side that is to be shortened in order to stabilise the component and reduce the risk of injury.

Detach the loose frame from the provisional fastening of the component, shorten the component as is required or necessary, push the loose frame as far as it will go, making sure it is flush with the component.

Fasten the loose frame by means of sealed blind rivets (maximum 150 mm distance between them) (Attention, do not use self-tapping screws!)

Subsequent, on-site sealing along the section frame, on the entire interior of the frame and inside the corners (use only sealants suitable for later use that is, for example, compliant with VDI 6022, solvent-free, etc.)

Do not fasten any additional attachments with self-tapping screws (only with sealed blind rivets).

Seal attachments afterwards using a suitable sealant (compliant with VDI 6022).

Flexible connectors, multi-leaf dampers, silencers etc. must be shown to meet the requirements of airtightness class C.

Leakage tests

On-site leakage tests in accordance with DIN EN 12599 are offered by external, independent contractors.

The tests should already be defined at the planning stage and carried out during the assembly stage. See the information sheet "Measuring airtightness of ducting systems" (see, www.berlinerluft.de – downloads)